

Stability of emulsion from bio-oil and diesel oil and combustion experimental study of emulsion

Huang Yaji*, Zhong Zhaoping, Jin Baosheng, Li Bin, Sun Yu

Thermal Engineering Research Institute; Southeast University, Nanjing 210096, China

By using emulsifiers of Span-80 and Tween-80, the emulsion was prepared by bio-oil and diesel oil. The effect of HLB value and volume fraction of bio-oil on the stability of emulsion was studied. The combustion and gaseous pollutants characteristics of emulsion were also studied in the paper. The results may be summarized as follows: when the volume fraction of bio-oil is not more than 15% and the HLB value is between 7.0 and 8.0, emulsion can remain stable. With the increase of oxygen in flue gas, the combustion temperature and the NOX concentration of emulsion are increased, and the concentrations of SO₂ and CO are decreased. The combustion temperature and the concentrations of SO₂, NOX and CO of emulsion are lower than those of diesel oil at the same flue gas oxygen. Compared with diesel oil flame, the flame of emulsion has higher brightness and the outer edge of flame shows cross-flash phenomenon. Emulsion can be used as an alternative oil fuel, but the questions of lower acidity, larger exhaust heat loss, higher viscosity should be pay more attention.

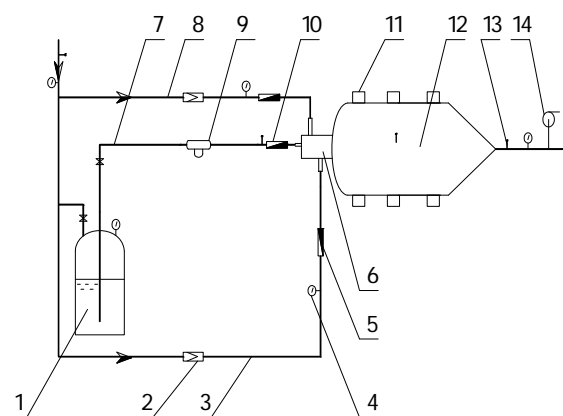

1.oil tank 2. pressure reducing valve 3. combustion air tube 4. pressure meter 5. air flow meter 6. burner 7. oil pipe 8. atomization air pipe 9. oil filter 10. oil flow meter 11. observation hole 12. horizontal furnace 13. thermocouple 14.flue gas analyzer

Fig.1 Emulsion combustion process

References

- [1] Bai Xueyuan, Wu Juan, Wang Lihong, et al. (2009) Preparation of emulsified fuel from biomass pyrolysis derived bio-oil and diesel and their use in engine. *Transactions of the Chinese Society for Agricultural Machinery* 40, 112-115.
- [2] Michio Ikura, Maria Stanculescu, Ed Hogan (2003). Emulsification of pyrolysis derived bio-oil in diesel oil. *Biomass and Bioenergy* 24, 221-232.
- [3] Wang Liming, Wang Shuyang (2008). Physical and chemical characteristics of bio-oil/diesel emulsified fuel. *Acta Energiæ Solaris Sinica* 29, 536-538.
- [4] Zhou Qinghui, Ji Wei, Fu Taijun (2007) Experiment study on diesel engine of Methanol-Biodiesel-Diesel Micro-emulsion. *Tractor & Farm Transporter* 34, 4-6.
- [5] Zhu Xifeng, Guo Tao, Lu Qiang, et al. (2005) Research on the Characteristics of Bio-oil Combustion. *Journal of University of Science and Technology of China* 35, 856-860.
- [6] Wang Shurong, Luo Zhongyang, Dong Liangjie, et al. (2002) Flash pyrolysis of biomass for bio-oil in a fluidized bed reactor. *Acta Energiæ Solaris Sinica* 23, 4-10.
- [7] Yu Jiye, Peng Yanli, Li Yanfei (2007) Stability of emulsion from bio-oil and diesel. *Journal of Shandong University of Technology* 21, 101-103.
- [8] Jamil Ghojel, Damon Honnery, Khaled Al-Khaleefi (2006) Performance emissions and heat release characteristics of direct injection diesel engine operating on diesel oil emulsion. *Applied Thermal Engineering* 26, 2132-2141.
- [9] Gong Jingsong, Wang Chao, Zhang Bo, et al. (2005) A Re-study on the Effect of Emulsion on the BSFC and Environmental Protection in the Diesel Engine. *Internal Combustion Engines* 6, 44-46.
- [10] Chen S K, Lefebvre A H, Rollbuhler J et al. (1993) Influence of Ambient Air Pressure of Effervescent Atomization. *Journal of Propulsion and Power* 9, 10-15.
- [11] Gu Yujiong, Yang Kun (1997) Study on the ultrasonic emulsion technology of the burning oil added with water. *Modern Electric Power* 14, 6-10.
- [12] Dung N, Damon H. (2008) Combustion of bio-oil ethanol blends at elevated pressure. *Fuel* 87, 232-243.